

# Series ECC Column Covers

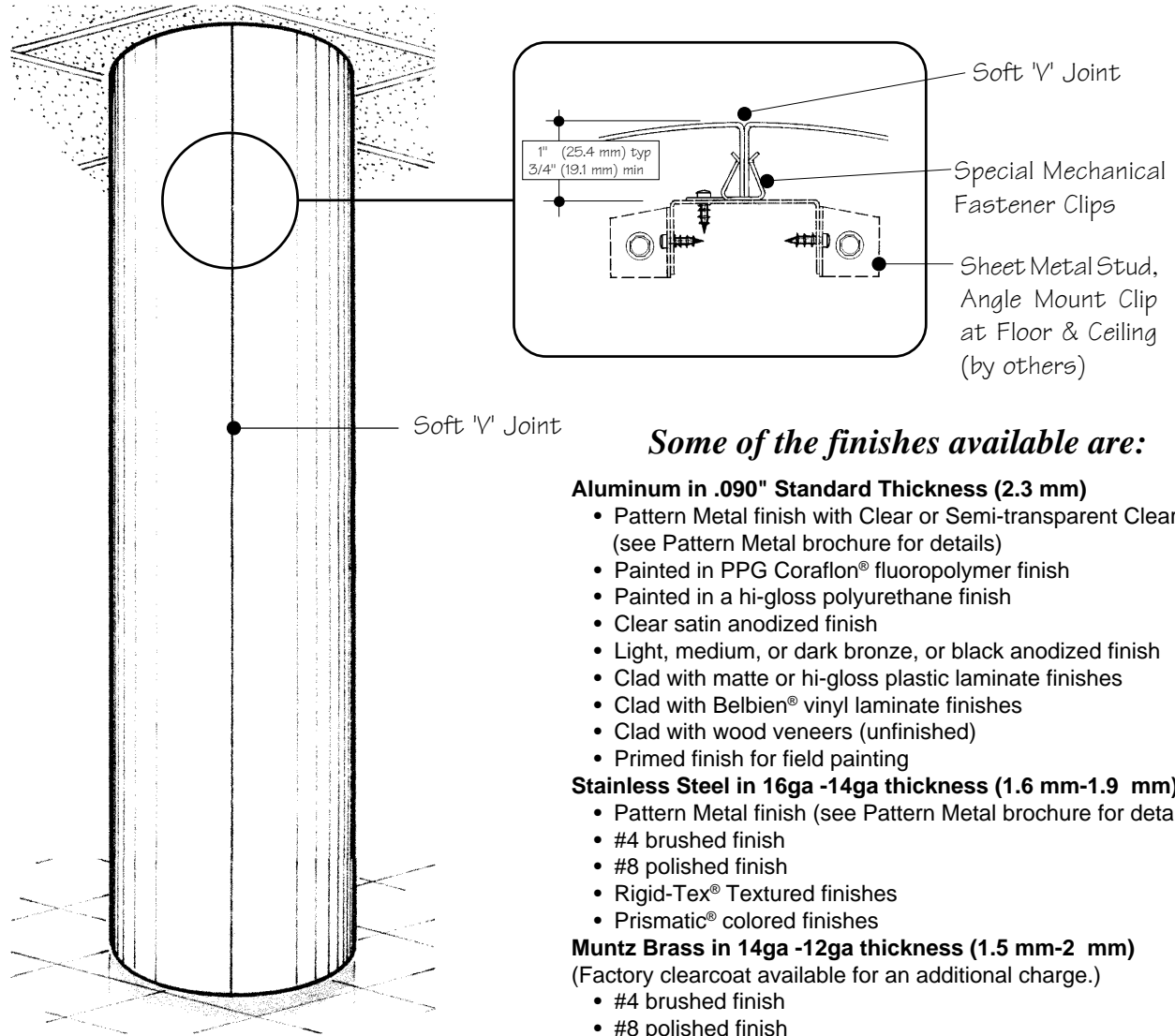

**SERIES ECC Column Cover**

No Scale

### Some of the finishes available are:

#### Aluminum in .090" Standard Thickness (2.3 mm)

- Pattern Metal finish with Clear or Semi-transparent Clear-coat (see Pattern Metal brochure for details)
- Painted in PPG Coraflon® fluoropolymer finish
- Painted in a hi-gloss polyurethane finish
- Clear satin anodized finish
- Light, medium, or dark bronze, or black anodized finish
- Clad with matte or hi-gloss plastic laminate finishes
- Clad with Belbien® vinyl laminate finishes
- Clad with wood veneers (unfinished)
- Primed finish for field painting

#### Stainless Steel in 16ga -14ga thickness (1.6 mm-1.9 mm)

- Pattern Metal finish (see Pattern Metal brochure for details)
- #4 brushed finish
- #8 polished finish
- Rigid-Tex® Textured finishes
- Prismatic® colored finishes

#### Muntz Brass in 14ga -12ga thickness (1.5 mm-2 mm)

(Factory clearcoat available for an additional charge.)

- #4 brushed finish
- #8 polished finish

*Other materials and thicknesses are available as options. Check with the factory for your requirements. Finishes meet or exceed AAMA standards for scratches or blemishes.*

Coraflon® is a registered trademark of PPG Industries.  
Rigid-Tex® is a registered trademark of Rigidized Metals Corp.  
Prismatic® is a registered trademark of B & M Finishers, Inc.  
Belbien® is a registered trademark of the C.I. Kasei Company, LTD of Japan.

The SERIES ECC SNAP-LOCK column cover fulfills the basic needs of many modestly budgeted projects. It is a viable alternative to the more costly SERIES 1500 column cover, with customer supplied posts, and gives a soft 'V' joint when the column cover is installed. They are available in the same finishes as the rest of our column cover lines and just as easily installed. The SERIES ECC is supplied in two equal halves with continuous installation fins bent along each side. When installed, these fins fit into special metal locking clips, which are factory provided. Sizes available range from a minimum of 12" in diameter (304.8 mm), up to 30" in diameter (762 mm), with a single length height up to 16' (4.877 M). (Note: Use minimum of 16" in diameter (406.4 mm) for column covers greater than 12' in height.) Larger diameters are possible with the addition of vertical joints, so check the factory for your particular requirements. As a standard, the SERIES ECC is manufactured using 16ga .062" (1.6 mm) electrogalvanized steel.

# Series ECC-Details & Installation

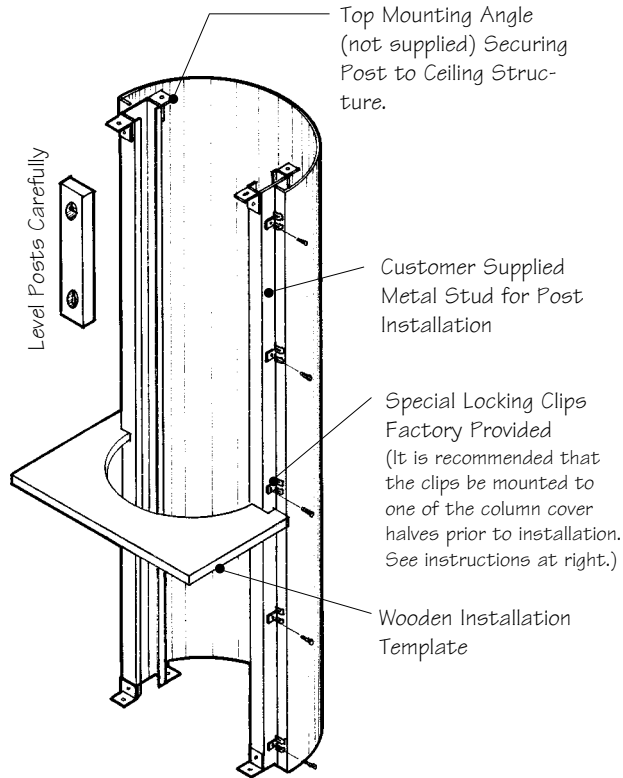

Installation Details

No Scale

The SERIES ECC column cover system consists of the following parts:

- 1) Two custom roll-formed column cover halves.
- 2) Special locking clips for installation.
- 3) One set of drawings / instructions.

The following customer supplied parts are also required for proper installation:

- 1) Two 2-1/2" metal or wood studs.
- 2) Angle brackets or runner channel for securing studs to floor and ceiling.
- 3) Plumb bob & carpenter's level.
- 4) 1/8" or similar size drill bit.
- 5) #8 pan head Phillips sheet metal screws (for securing locking clips to metal studs).

The proper positioning and anchoring of the metal studs is the single most important aspect of installing the SERIES ECC column cover. The studs must be plumb and properly spaced from one another, and the mounting brackets securely fastened to the floor and ceiling in order for the column cover halves to properly install. For specific installation instructions, please refer to the detailed installation instructions below, or in case of further questions, consult the factory.

## Typical installation procedure

- 1) Determine the position of the column cover around whatever structural member you wish to enclose, and then install one stud in place, using a plumb bob and level to ensure plumbness. Position the opposite stud in place so that the two studs are 2-1/8" closer together (2-7/8" W/ reveals) than the diameter of the column cover halves. Make sure that studs are securely fastened to the ceiling and floor utilizing proper fasteners.
- 2) Attach the special locking clips over the installation fins of one column half. Position column half so that the clips align down the center of both studs. Attach the clips to the posts. Position the second column cover half so that one installation fin mounts inside the locking clips and spring the other side around the opposite post, using a glazing tool if necessary to spring the cover open. Do not over stretch column cover.
- 3) Using a heavily padded 2x4 and a rubber mallet, firmly strike both column halves at the joints to seat fins. Begin at the bottom and work your way up. This will ensure proper installation of the column cover.

## SAMPLE SPECIFICATION

### Section 05-58-13 Architectural Metal Column Covers

#### Part 1 - General

##### 1.01 Description of work

A. Furnish all material necessary for a complete installation of the SERIES ECC column covers, exclusive of field applied material (i.e. joint compound, substructure, etc.).

##### 1.02 Submittals

A. Submit complete shop drawings detailing quantities, sizes, finish, configurations, and column attachment methods.

B. Submit product literature, specifications, information, and installation instructions.

##### 1.03 Quality Assurance

A. Manufacturer to have a minimum of ten years experience in the manufacturing of column covers.

B. Manufacturer to inspect all aspects of the product to ensure that specifications have been met, and that they comply with approved shop drawings.

C. Manufacturer shall issue a one year limited warranty ensuring product against defects in workmanship and materials.

#### Part 2 - Products

##### 2.01 Acceptable Manufacturers

**Pittcon Industries**  
6409 Rhode Island Ave.  
Riverdale, MD 20737

**Pittcon Industries**  
3330 W. Flower Street  
Phoenix, Arizona 85017

##### 2.02 Materials

A. Column covers shall be roll-formed from (specified material) with (specified finish) to match architects sample.

B. All fasteners are to be concealed.

C. All column covers are to be shipped with protective material on all exposed surfaces.

##### 2.03 Fabrication

A. Column covers shall be roll-formed to specific dimensions and tolerances, and accurately formed to radii shown on drawings.

B. Column covers shall be fabricated in two vertically divided sections with attachment provided through bent-back installation fins.

#### Part 3 - Execution

##### 3.01 Inspection & Installation

A. Contractor to inspect column covers upon receipt to ensure that no damage has occurred during shipment.

B. Column cover to be correctly oriented and installed in accordance with manufacturer's shop drawings and installation instructions to ensure proper installation.

C. Column cover to be erected plumb and level.

##### 3.02 Cleaning & Protection

A. Contractor to remove protective material supplied by column cover manufacturer.

B. Contractor to clean all visible surfaces after installation.

C. Contractor to protect column covers from damage by other trades

## Pittcon Industries Division Pittcon Architectural Metals, LLC

6409 Rhode Island Avenue  
Riverdale, Maryland 20737  
(800) 637-7638 , (301) 927-1000  
Fax: (301) 699-8690

3330 W. Flower Street  
Phoenix, Arizona 85017  
(800) 637-7638 , (602) 233-9100  
Fax: (602) 233-9400

© 2008 Pittcon Industries

Fabricated with Pride in



Riverdale, Maryland-U.S.A.