

Perimeter Trims

by Pittcon Industries

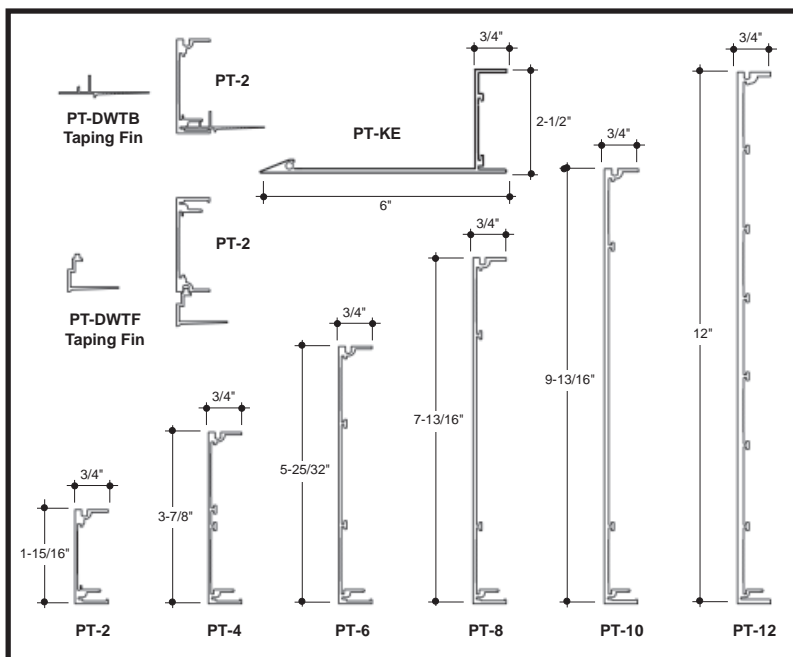

Sizes: 2" to 12" Tall

Straight Lengths

Factory Curving

Inside & Outside Corners

Drywall Taping Flanges

Ceiling Grids

Acoustical Tiles

Perimeter Trims

Typical Installation

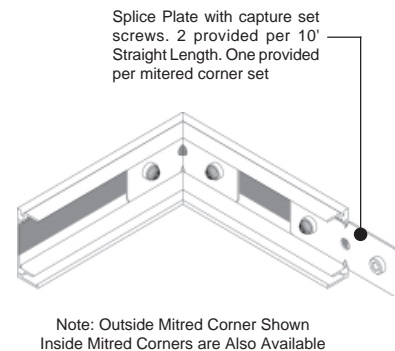
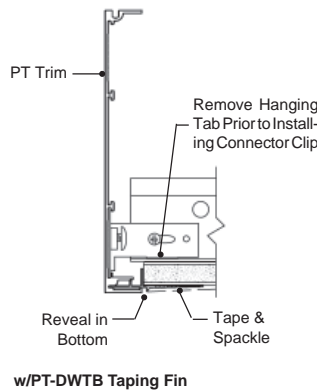
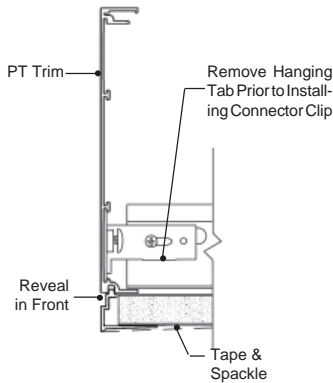
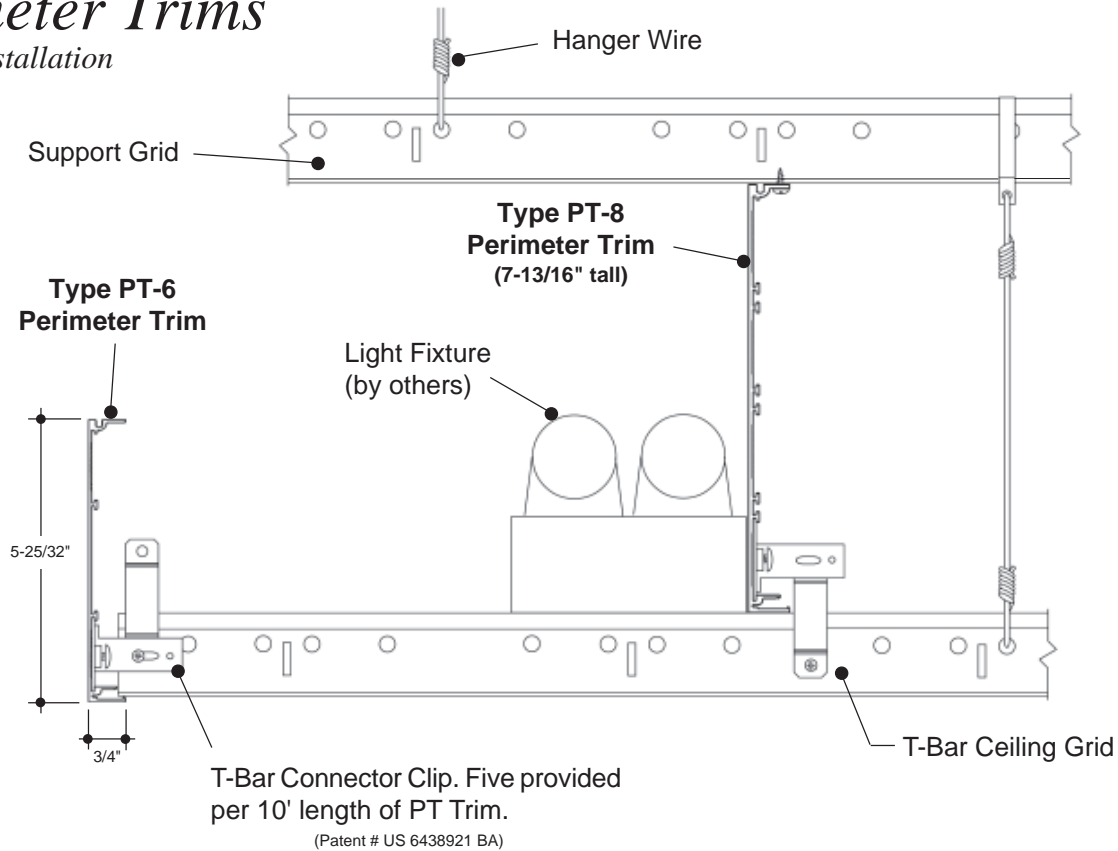

Pittcon Industries offers a line of Perimeter Trims uniquely designed to provide the architect or interior designer with a choice of a smooth, unbroken surface at the 3/4" wide bottom flange, or by simply flipping the perimeter trim over, a decorative reveal. The same utility is carried over in our selection of drywall taping fins, allowing for a decorative reveal on the face of the perimeter trim, or along the bottom edge (see above). Our selection of heights from 2" to 12" tall insure a full range from which to choose, allowing the creation of innovative and challenging designs. Please consult the factory or your local manufacturer's representative for details.

PT Model	Height at Face	Curving & Mitred Corners
PT-2	1-15/16" (49.2 mm)	PT TRIMS are available in the following sizes. Typical lengths are 10', with custom lengths available. Consult factory for details. All PT TRIMS other than the Knife Edge Trim can be factory curved in single radii or serpentine configurations within one 10' length. Consult factory for minimum radii and serpentine configurations. Typical yield from a stock 10' length is ±8'6", so plan your requirements accordingly. In addition, all PT TRIMS are available with inside and outside mitred corners, provided loose for field assembly, or with factory welded miters.
PT-4	3-7/8" (98.4 mm)	
PT-6	5-25/32" (146.8 mm)	
PT-8	7-13/16" (198.4 mm)	
PT-10	9-13/16" (249.2 mm)	
PT-12	12" (304.8 mm)	
PT-KE	6" (152.4 mm)	

Perimeter Trims

Knife Edge Installation

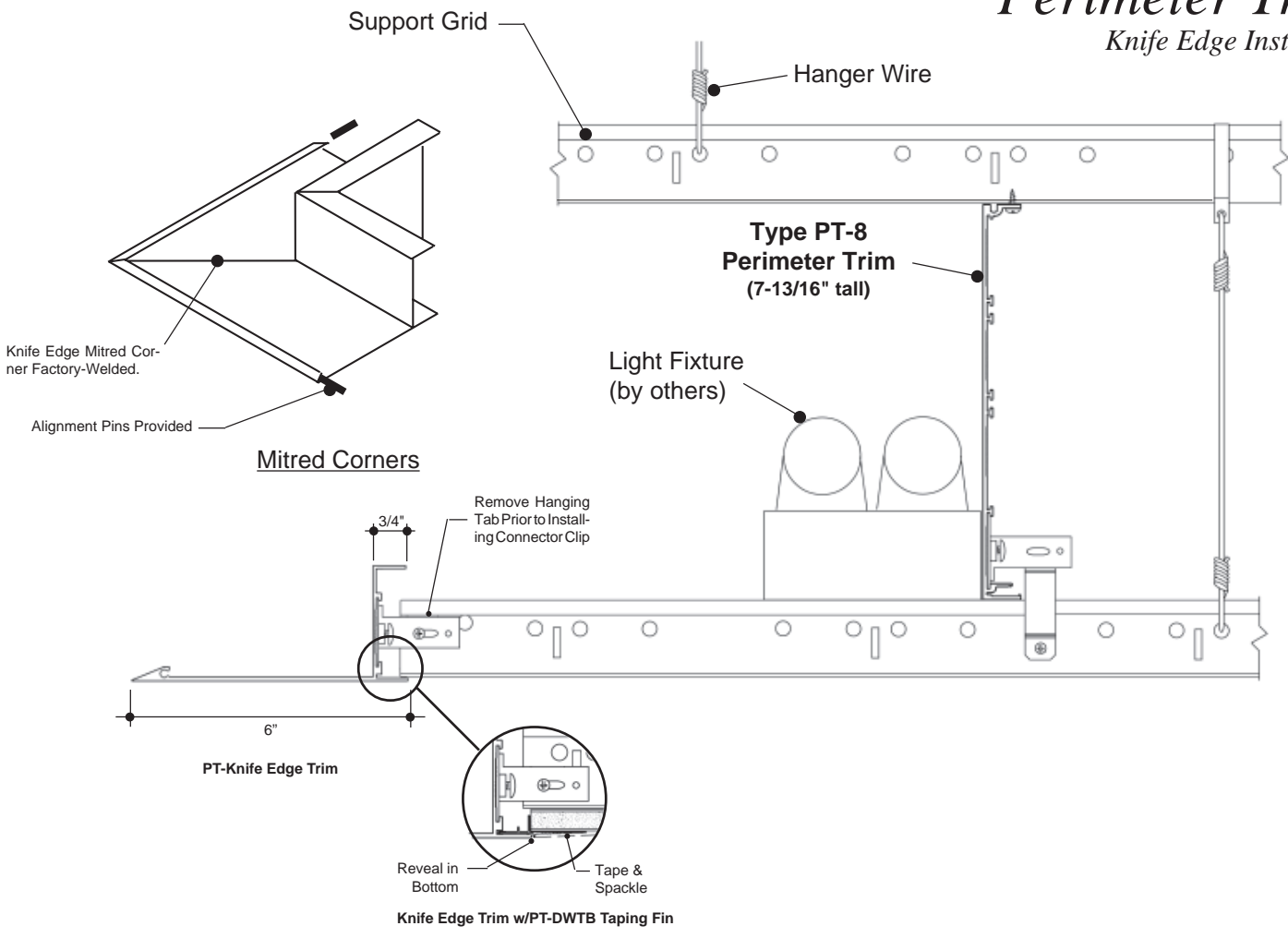

Perimeter Trims Specifications

SECTION 09 53 00 - ACOUSTICAL CEILING SUSPENSION ASSEMBLIES

PART 1 - GENERAL

1.01 SUMMARY

- A. Section includes metal trim for ceiling clouds and fascia.
- B. Related Sections:
 - 1. Section 09 53 13 - Curved Profile Suspension Assemblies
 - 2. Section 09 53 23 - Metal Acoustical Ceiling Suspension Assemblies

1.02 SUBMITTALS

- A. Manufacturer's product data.
- B. Samples: Representative samples of specified color and finish of exposed surfaces.
- C. Shop Drawings: Reflected ceiling plans to indicate trim locations, radii, and part numbers.
- D. LEED Submittals <Insert USGBC LEED credit references if required for the Project>

1.03 QUALITY ASSURANCE

- A. Qualifications:
 - 1. Manufacturer: Not less than 10 years experience manufacturing of specialty ceiling components.
 - 2. Installer: Not less than 5 years of experience in the installation of specialty ceiling components.
- B. Field-Constructed Mock-Up: In a location selected by the Architect, provide a field-constructed mock-up to demonstrate workmanship. Following approval, the mock-up may be incorporated into the Project.

PART 2 - PRODUCTS

2.01 MANUFACTURERS

Pittcon Industries	Pittcon Industries	Pittcon Industries
6409 Rhode Island Avenue	3330 West Flower Street	2090 Del Rio Way, Unit B
Riverdale, Maryland 20715	Phoenix, Arizona 85017	Ontario, California 91761

2.02 PERIMETER TRIM

- A. Material: Extruded 6063-T5 aluminum with factory-applied finish.
- B. Perimeter Trim:
 - 1. Height: <Select from the following> [2"] [4"] [6"] [8"] [10"] [12"].
 - 2. Horizontal Face Dimension: 3/4 inch.
 - 3. Corners: Factory mitered. 6" x 6" corner kits are allowed in place of mitered corners.
- C. Knife Edge Perimeter Trim:
 - 1. Height: 2-1/2"
 - 2. Horizontal Face Dimension: 6".
 - 3. Corners: Factory mitered. 6" x 6" corner kits are allowed in place of mitered corners.
- D. Connectors: Combination T-Bar type manufactured from galvanized steel with set screws for attaching perimeter trim to suspension system members.

2.03 FABRICATION

- A. Fabricate trim in standard lengths with continuous integral slots for attachment of splice plates and connectors.
- B. Fabricate products to specific dimensions and shapes shown on Drawings.
- C. Finish: Factory-applied; color selected by the Architect.

PART 3 - EXECUTION

3.01 EXAMINATION

- A. Inspect area receiving products with Installer present. Correct adverse conditions before proceeding

3.02 PREPARATION

- A. Verify adequate support for perimeter trim is in place prior to installation.

3.03 INSTALLATION

- A. Comply with ASTM C636 "Standard Practice for Installation of Metal Ceiling Suspension Systems for Acoustical Tile and Lay-In Panels", manufacturer's instructions, and details on Contract Drawings.
- B. Attach T-bar Connectors to perimeter trim by inserting into grooves and firmly tightening set screws. Attach combination T-bar connectors to main tees and cross tees in accordance with the manufacturer's instructions.

Pittcon Industries; Shaping The Future, One Project at a Time.

Pittcon Industries www.pittconindustries.com

6409 Rhode Island Ave.

Riverdale, MD 20737

Phone: (301) 927-1000

Fax: (800) 897-3129

3330 West Flower St.

Phoenix, AZ 85017

Phone: (602) 233-9100

Fax: (602) 233-9400

2090 Del Rio Way, Unit B

Ontario, CA 91761

Phone: (909) 773-0001

Fax: (909) 773-0091