

SBX

CUSTOM BOX-RECESSED

SAMPLE SPECIFICATION

specify as: SOFTFORMS® Model # SBX

Pitcon SOFTFORMS® LLC

6409 Rhode Island Avenue	3330 W. Flower Street
Riverdale, MD 20737	Phoenix, AZ 85017
(800) 637-7638	(800) 637-7638
(301) 927-1000	(602) 233-9100
Fax: (301) 699-8690	Fax: (602) 233-9400

The formed aluminum profile shall incorporate a continuous integral fin for surface contact to conventionally installed gypsum drywall. The fins shall be 1-1/4" wide nominal. The formed profile shall be primed with corrosion-resistant primer compatible with materials normally in use in conjunction with commercial interiors, i.e.: joint compound, latex and enamel paints, and wall covering adhesives.

MATERIAL: Aluminum alloy.....3003 H-14 or equal
 Finish.....Factory primed
 Metal thickness......062" typical

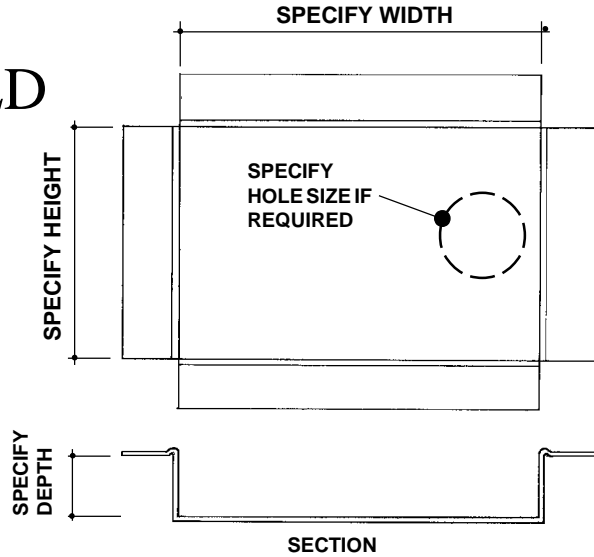

SBX
NO SCALE

RECESSED BOX
PLAN & SECTION

EXAMPLE DETAIL

For use with conventional metal stud construction and 1/2" or 5/8" GPDW.

The SBX may be specified in any dimension and is useful as a recessed switch/control box. Holes in the back plate can be punched to meet your requirements. Screws through the grooved fins must always engage metal or wood substructure to ensure proper installation.

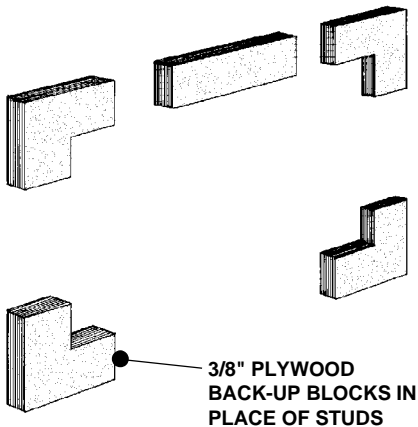

BACKUP BLOCKS (OPTIONAL)
NO SCALE PERSPECTIVE

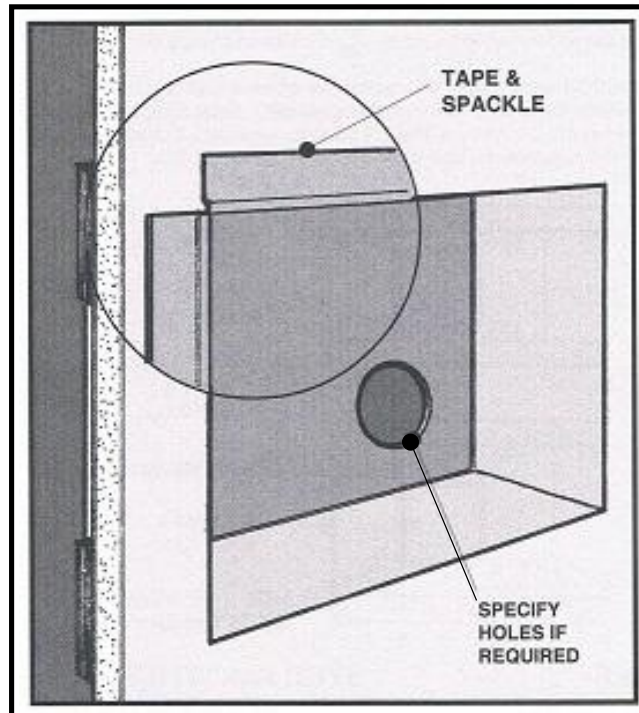

All details, methods and specifications are the exclusive property of Pitcon Softforms® LLC. Pitcon reserves the right to change any specifications or details without prior notification. All Softforms® profiles are available in standard 10' lengths ±1/8" (2.048 M). Other lengths are available as special order items. For custom shapes, sizes, or for special finishes, please contact the factory or your nearest Pitcon sales representative.