

SO-60A

60° OUTSIDE CORNER

SAMPLE SPECIFICATION

specify as: SOFTFORMS® Model # SO-60A

Pittcon SOFTFORMS® LLC

6409 Rhode Island Avenue
Riverdale, MD 20737
(800) 637-7638
(301) 927-1000
Fax: (301) 699-8690

3330 W. Flower Street
Phoenix, AZ 85017
(800) 637-7638
(602) 233-9100
Fax: (602) 233-9400

The extruded aluminum profile shall incorporate a continuous integral fin for surface contact to conventionally installed gypsum drywall. The fins shall be 7/8" wide and shall be tapered to the edge. The tapered fins shall be punched with holes staggered to accept standard screw fastening. A series of continuous grooves shall be extruded into the face of the fins to provide greater bonding surface. The extruded profiles shall be primed with corrosion-resistant primer compatible with materials normally in use in conjunction with commercial interiors, i.e.: joint compound, latex and enamel paints, and wall covering adhesives.

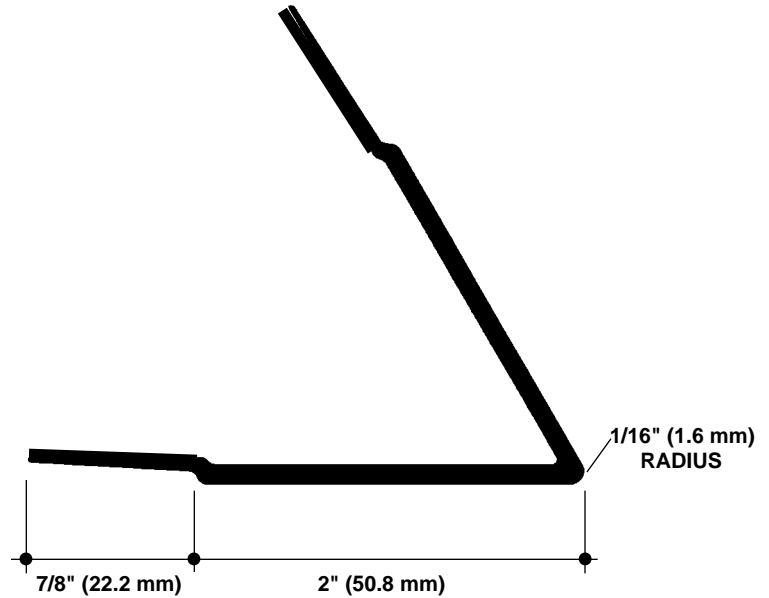

MATERIAL: Aluminum alloy.....6063 T5 or equal
Finish.....Factory primed

SO-60A
NO SCALE

60° OUTSIDE CORNER
SECTION

EXAMPLE DETAIL

For use with conventional metal stud construction and 1/2" or 5/8" GPDW.

The SO-60A provides a true and durable 60° corner. When combined with wood cabinetry the adjoining panels must be rabbeted to permit recessing the fins. These areas are finished with fiberglass body putty and feathered out. Screws through the grooved fins must always engage metal or wood substructure to ensure proper installation.

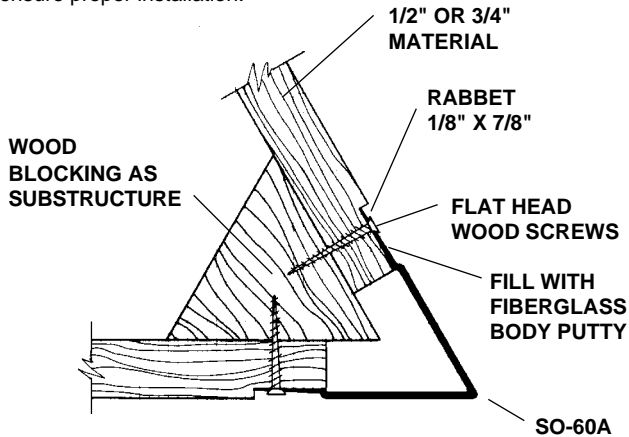

SO-60A @ PEDESTAL CORNER
NO SCALE **SECTION**

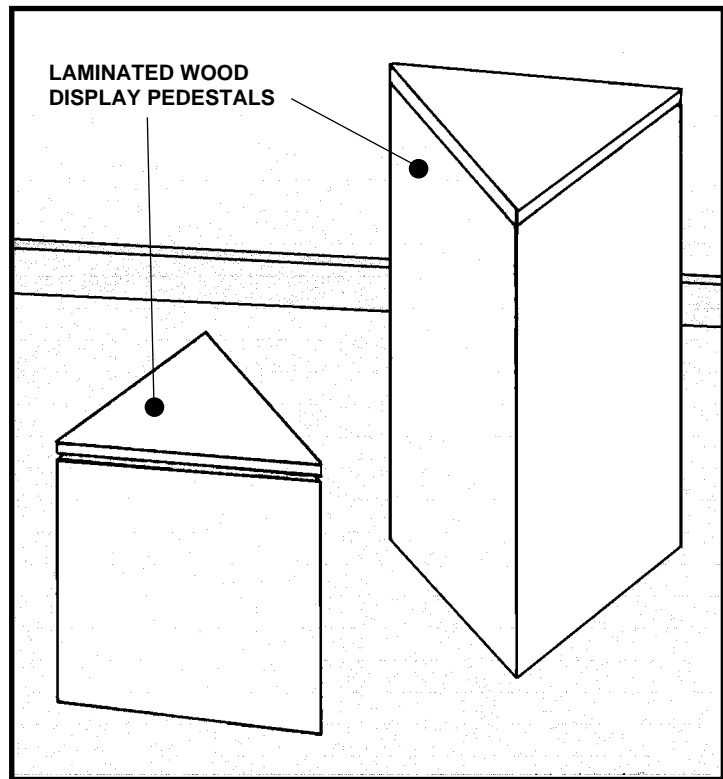

All details, methods and specifications are the exclusive property of Pittcon Softforms® LLC. Pittcon reserves the right to change any specifications or details without prior notification. All Softforms® profiles are available in standard 10' lengths ±1/8" (2.048 M). Other lengths are available as special order items. For custom shapes, sizes, or for special finishes, please contact the factory or your nearest Pittcon sales representative.