

LC-9-PF

Triple Step Radius Light Cove

SAMPLE SPECIFICATION

Specify as: PITTCON LIGHT COVE

Model # LC-9-PF	Perpendicular Fin
Model # LC-9-TF	Tangential Fin
Model # LC-9-WM	Wall Mounting

Material: Aluminum alloy.....3003 H-14 or equal
Finish.....Factory primed
Metal thickness......090" typical

The formed aluminum profile shall incorporate a continuous integral fin for surface contact to conventionally installed gypsum drywall. The formed profile shall be primed with corrosion-resistant primer compatible with joint compound, latex and enamel paints, and wall covering adhesives.

Other materials and finishes are available with some restrictions applying, due to sconce and butt joint options. Contact factory or your local Pittcon sales representative for details.

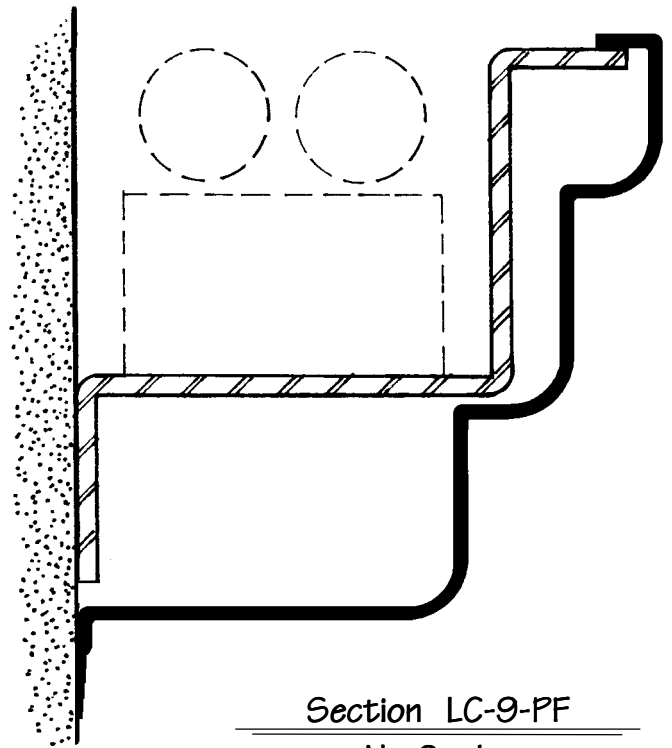

Section LC-9-PF

No Scale

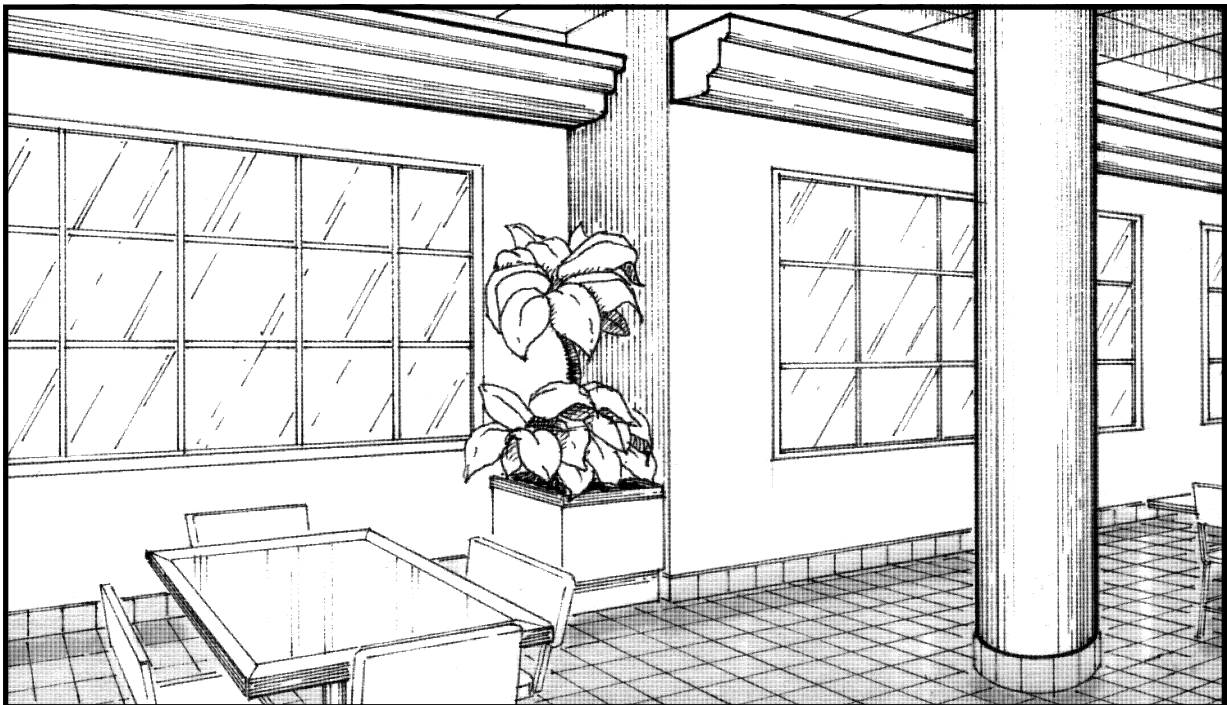

All details, methods and specifications are the exclusive property of Pittcon Industries, Division of Pittcon Custom Corporation. Pittcon reserves the right to change any specifications or details without prior notification. All Light Cove profiles are available in standard 10' lengths $\pm 1/8"$ (2.048 M). Other lengths are available as special order items. For custom shapes, sizes, or for special finishes, please contact the factory or your nearest Pittcon sales representative.

Pittcon Industries Division Pittcon Architectural Metals, LLC

6409 Rhode Island Avenue
Riverdale, Maryland 20737
(800) 637-7638 , (301) 927-1000
Fax: (301) 699-8690

3330 W. Flower Street
Phoenix, Arizona 85017
(800) 637-7638 , (602) 233-9100
Fax: (602) 233-9400

Pittcon Industries

DIVISION OF PITTCON CUSTOM CORPORATION

Fin Options

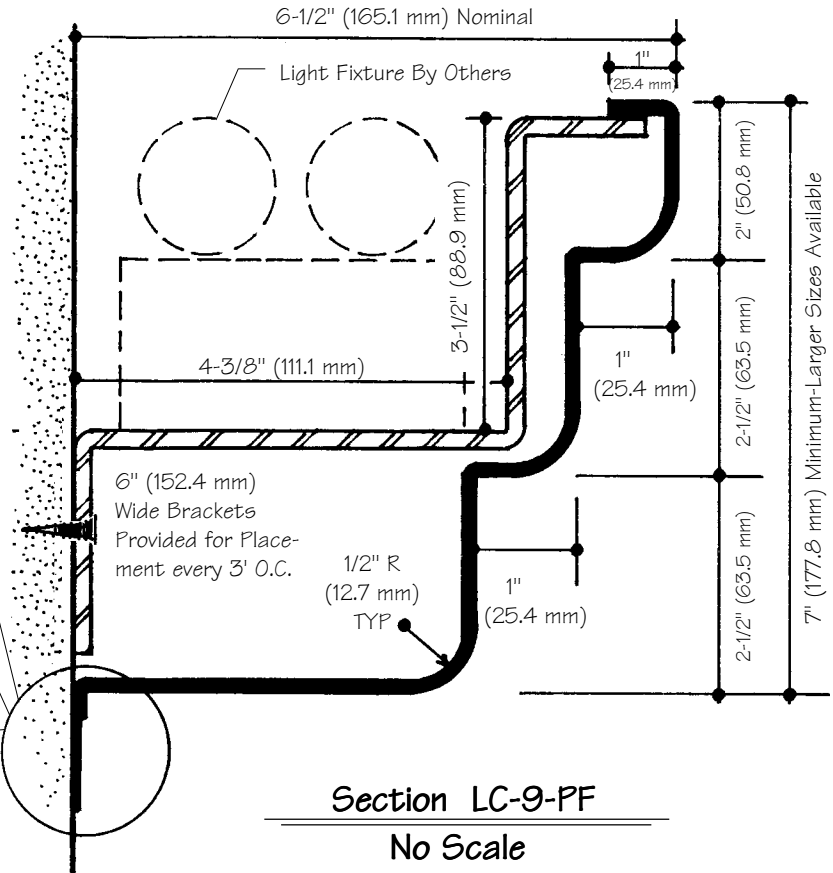
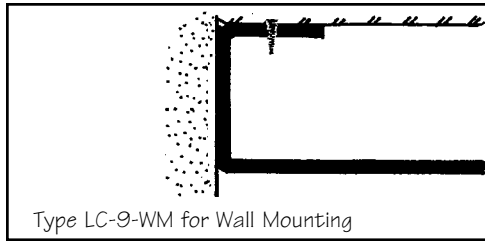
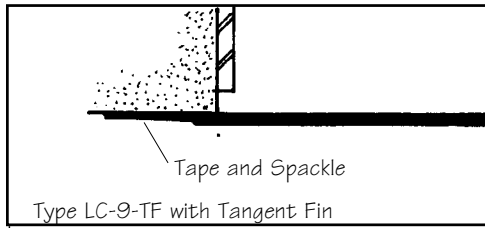
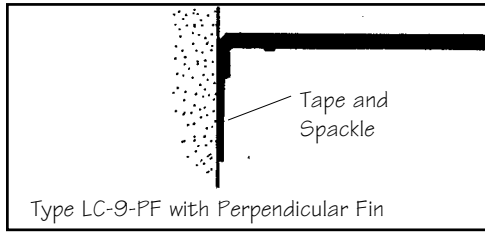

Joint Details

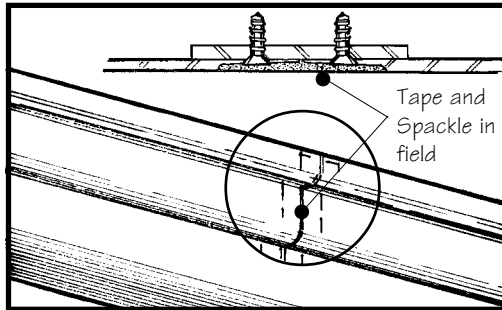

End Caps Loose or
Factory Welded

Special Options

Wall Sconce Option

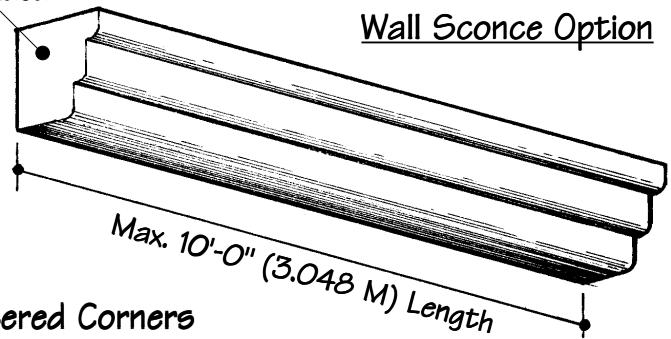

Factory Mitered Corners

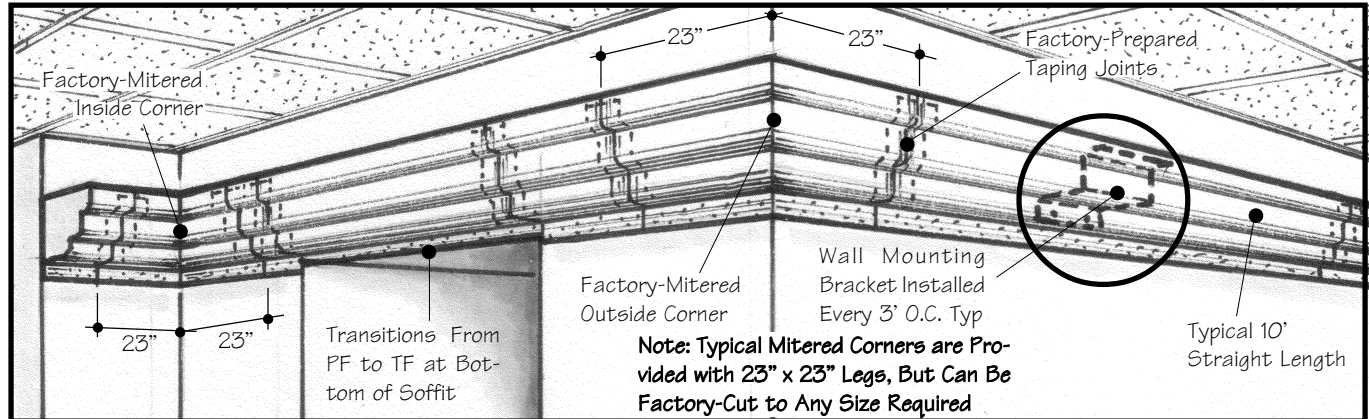

Pittcon Industries Division Pittcon Architectural Metals, LLC

6409 Rhode Island Avenue
Riverdale, Maryland 20737
(800) 637-7638 , (301) 927-1000
Fax: (301) 699-8690

3330 W. Flower Street
Phoenix, Arizona 85017
(800) 637-7638 , (602) 233-9100
Fax: (602) 233-9400

**Pittcon
Industries**

DIVISION OF PITTCON ARCHITECTURAL METALS, LLC